

# MINI STRONG

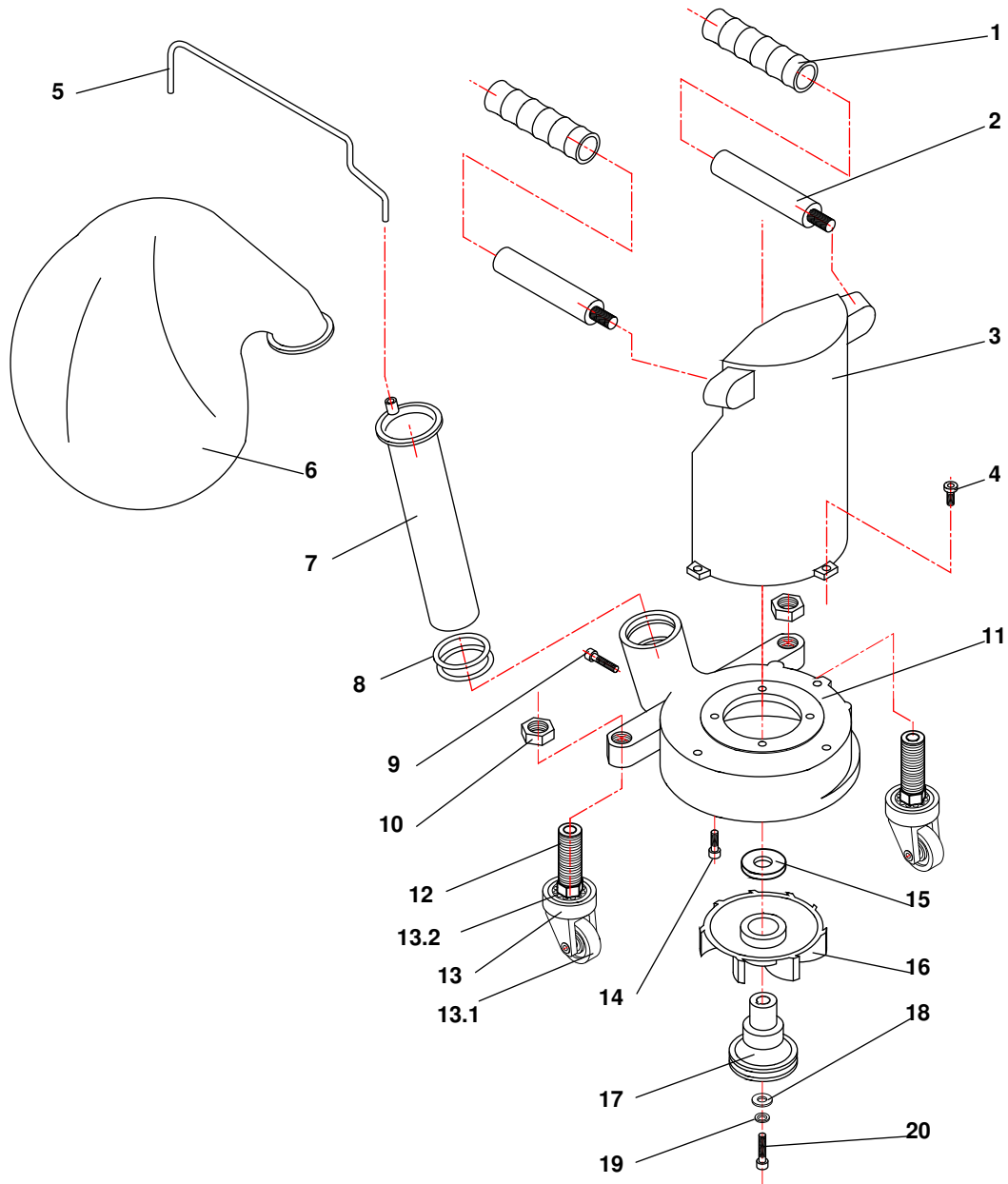

# MINI STRONG

Nº	DESCRIPCIÓN	DESCRIPTION	REFER.	EURO
1	EMPUÑADURA	HILT	0EMP2200001	1,66
2	MANILLAR	HANDLE	00122012	4,64
	MANILLAR COMPLETO	HANDLE COMPLETE	00122012COM	7,06
3	SOPORTE VERTICAL	UPPER FRAME	00122004	120,50
4	TORNILLO DIN 912 M 6 x 16	SCREW DIN 912 M 6 x 16	40016060162	0,32
5	VARILLA	DUST BAG CLAMP	00120013	3,28
6	SACO	DUST BAG	0SAC1200002	15,30
7	TUBO DE ASPIRACIÓN	SUCTION TUBE	00120007	40,78
8	JUNTA TÓRICA OR 44,2 X 3	O RING OR 44,2 X 3	70026203934	3,40
9	TORNILLO DIN 912 M 6 x 30	SCREW DIN 912 M 6 x 30	40016060302	0,77
10	TUERCA DIN 439 M 16 x 1,5	NUT DIN 439 M 16 x 1,5	40204161502	0,97
11	CARCASA DE ASPIRACIÓN	FAN HOUSING	00122001	146,76
12	PORTA RUEDA	WHEEL BRACKET	00124016	4,04
13	CONJUNTO RUEDA GIRATORIA	SWIVEL WHEEL Ø 40	0RUE4000003	16,11
13.1	RUEDA Ø 40	WHEEL Ø 40	0RUE4000004	2,36
13.2	RODAMIENTO 6200 KBC 2RS	BALLBEARING 6200 KBC 2RS	50010620000	7,23
14	TORNILLO DIN 912 M 6 x 16	SCREW DIN 912 M 6 x 16	40016060162	0,32
15	DISTANCIADOR DEL MOTOR	MOTOR SPACER	00122008	4,18
16	ASPIRADOR	FAN	00122003	61,66
17	POLEA DEL MOTOR	MOTOR PULLEY	00122007	57,29
18	ARANDELA DE APRIETE	WASHER	00122009	4,28
19	ARANDELA DIN 7980 M 5	WASHER DIN 7980 M 5	40323050321	0,32
20	TORNILLO DIN 912 M 5 X 25	SCREW DIN 912 M 5 X 25	40016050252	0,32

# MINI STRONG

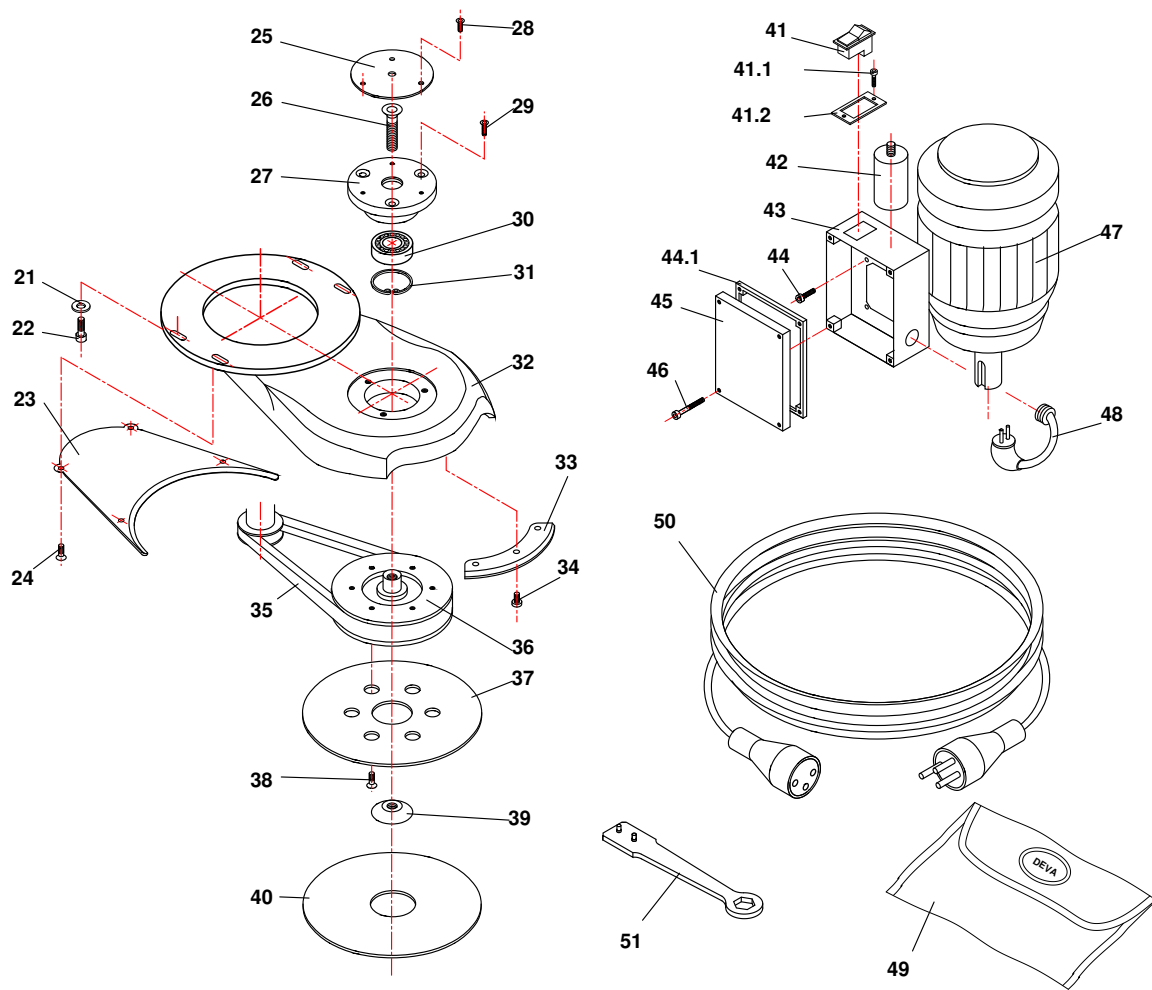

# MINI STRONG

Nº	DESCRIPCIÓN	DESCRIPTION	REFER.	EURO
21	ARANDELA DIN 125 M 6	WASHER DIN 125 M 6	40301060161	0,32
22	TORNILLO DIN 912 M 6 x 20	SCREW DIN 912 M 6 x 20	40016060202	0,32
23	TAPA DE CORREAS	V-BELT COVER	00122006	20,28
24	TORNILLO DIN 963 M 5 x 12	SCREW DIN 963 M 5 x 12	40047050122	0,32
25	TAPA SUPERIOR	COVER	00124035	8,93
26	TORNILLO DIN 7991 M 10 x 40	SCREW DIN 7991 M 10 x 40	40048100402	1,09
27	TAPA PORTA RODAMIENTO	BALLBEARING HOUSING	00124021	44,80
28	TORNILLO DIN 963 M 4 x 12	SCREW DIN 963 M 4 x 12	40047040122	0,32
29	TORNILLO DIN 963 M 6 x 20	SCREW DIN 963 M 6 x 20	40047060202	0,32
30	RODAMIENTO 3203 VVC 3	BALLBEARING 3203 VVC 3	50020320300	32,74
31	SEEGER I 40	SEEGER I 40	40325040171	0,77
32	BRAZO	SANDING ARM	00122005	183,45
33	PROTECTOR (disco ø 150mm)	COVER PLATE ø 150	00122015	11,91
34	TORNILLO DIN 84 M 5 x 12	SCREW DIN 84 M 5 x 12	40029050122	0,32
35	CORREA ZX 21 1/2	BELT ZX 21 1/2	70601110545	6,07
36	POLEA (disco ø 150mm)	PULLEY (disc ø 150 mm)	00122010	49,43
37	DISCO DE ACERO ø 150mm	STEEL DISC ø 150 mm	00120011	15,61
38	TORNILLO DIN 963 M 5 x 12	SCREW DIN 963 M 5 x 12	40047050122	0,32
39	TUERCA CÓNICA	CONICAL NUT	00124008A	3,01
40	VELCRO ø 150 mm	VELCRO ø 150 mm	00120020	4,32
40	FIELTRO ø 150 mm	FELT DISC ø 150 mm	00120036	2,80
41	INTERRUPTOR EUROPA	SWITCH EUROPA	0INT1300007	19,64
41.1	TORNILLO DIN 84 M 4 X 8	SCREW DIN 84 M 4 x 8	40029040082	0,32
41.2	BASE INTERRUPTOR	SWITCH BASE	00120043	1,99
42	CONDENSADOR 20 MF	CAPACITOR 20 MF	0CON1100013	15,00
43	CAJA ELÉCTRICA	ELECTRIC BOX	00122018	22,53
44	TORNILLO DIN 84 M 4 x 12	SCREW DIN 84 M 4 x 12	40029040122	0,32
44.1	JUNTA CAJA ELÉCTRICA	ELECTRIC BOX GASKET	00122019	4,18
45	TAPA CAJA ELÉCTRICA	SWITCH BOX COVER	00122014	9,14
46	TORNILLO DIN 7981 ST M 3,5 x 16	SCREW DIN 7981 ST M 3,5 x 16	40035350161	0,32
47	MOTOR 220-240V/50Hz	MOTOR 220-240V/50Hz	0MOT1100016	225,16
48	CABLE CON ENCHUFE CON T	CABLE WITH PLUG (GROUNDED)	0CAEL000006	8,85
49	BOLSA HERRAMIENTAS VACIA	TOOL BAG EMPTY	0BOL0000010	10,54
49	BOLSA HERRAMIENTAS COMPLETA	TOOL BAG COMPLETE	0BOLH200010	51,98
50	CABLE ALARGADERA CON T	CABLE CORD (GROUNDED)	0CAEL000009	22,48
51	LLAVE	KEY	00120052	8,48
	LLAVE PIPA	PIPE KEY	4500100017P	9,33
	ARANDELA CÓNICA	CONICAL WASHER	00124008	3,01
	TUERCA ARANDELA CÓNICA	NUT CONICAL WASHER	00124009	1,53